

Metallized Polyester (PET) SMD Film Capacitors with Box Encapsulation

Special Features

- Size codes 1812, 2220, 2824, 4030, 5040 and 6054 with PET and encapsulated
- Operating temperature up to 100° C
- Self-healing
- According to RoHS 2002/95/EC *

Typical Applications

For general DC-applications e.g.

- By-pass
- Blocking
- Coupling and decoupling
- Timing

Construction

Dielectric:

Polyethylene-terephthalate (PET) film

Capacitor electrodes:

Vacuum-deposited

Internal construction:

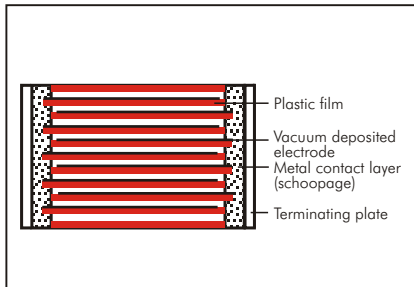

Encapsulation:

Solvent-resistant, flame-retardent plastic case, UL 94 V-0

Terminations:

Tinned plates.

Marking:

Colour: Black.

Marking (from size code 4030): Silver.

Electrical Data

Capacitance range:

1000 pF to 6.8 μ F

Rated voltages:

63 VDC, 100 VDC, 250 VDC, 400 VDC, 630 VDC, 1000 VDC

Capacitance tolerances:

$\pm 20\%$, $\pm 10\%$, ($\pm 5\%$ available subject to special enquiry)

Operating temperature range:

-55° C to +100° C

Climatic test category:

55/100/21 according to IEC

for size codes 1812 to 2824

55/100/56 according to IEC

for size codes 4030 to 6054

Insulation resistance at +20° C:

U_r	U_{test}	$C \leq 0.33 \mu F$	$0.33 \mu F < C \leq 6.8 \mu F$
63 VDC 100 VDC	50 V 100 V	$\geq 3.75 \times 10^3 M\Omega$ (mean value: $1 \times 10^4 M\Omega$)	$\geq 1250 \text{ sec} (M\Omega \times \mu F)$ (mean value: 3000 sec)
≥ 250 VDC	100 V	$\geq 1 \times 10^4 M\Omega$ (mean value: $5 \times 10^4 M\Omega$)	$\geq 3000 \text{ sec} (M\Omega \times \mu F)$ (mean value: 10 000 sec)

Measuring time: 1 min.

Dissipation factors at +20° C: $\tan \delta$

at f	$C \leq 0.1 \mu F$	$0.1 \mu F < C \leq 1.0 \mu F$	$C > 1.0 \mu F$
1 kHz	$\leq 8 \times 10^{-3}$	$\leq 8 \times 10^{-3}$	$\leq 10 \times 10^{-3}$
10 kHz	$\leq 15 \times 10^{-3}$	$\leq 15 \times 10^{-3}$	-
100 kHz	$\leq 30 \times 10^{-3}$	-	-

Maximum pulse rise time: for pulses equal to the rated voltage

Capacitance $\mu F/\mu F$	Pulse rise time $V/\mu sec$ max. operation/test					
	63 VDC	100 VDC	250 VDC	400 VDC	630 VDC	1000VDC
1000 ... 6800	35/350	35/350	40/400	50/500	-	-
0.01 ... 0.022	30/300	35/350	40/400	35/350	40/400	50/500
0.033 ... 0.068	20/200	20/200	40/400	21/210	25/250	32/320
0.1 ... 0.22	10/100	10/100	12/120	14/140	17/170	-
0.33 ... 0.68	8/80	6/60	9/90	10/100	-	-
1.0 ... 2.2	3.5/35	4/40	7/70	-	-	-
3.3 ... 6.8	3/30	3/30	-	-	-	-

Dip Solder Test/Processing

Resistance to soldering heat:

Test Tb in accordance with DIN IEC 60068-2-20/EN 132 200.

Soldering bath temperature max. 260° C.

Soldering duration max. 5 sec.

Change in capacitance $\Delta C/C < 5 \%$.

Soldering process:

Wave soldering and re-flow soldering.

Packing

Available taped and reeled in 12 mm blister pack.

Detailed taping information and graphs see WIMA main catalogue 2005.

* as of Mai 2006

Continuation

General Data

Capacitance	63 VDC/40 VAC*		100 VDC/63 VAC*		250 VDC/160 VAC*		400 VDC/200 VAC*		630 VDC/300 VAC*		1000 VDC/400 VAC*	
	Size Code	H ±0.3	Size Code	H ±0.3	Size Code	H ±0.3	Size Code	H ±0.3	Size Code	H ±0.3	Size Code	H ±0.3
1000 pF	1812	2.0	1812	2.0	1812	2.0						
1500 "	1812	2.0	1812	2.0	1812	2.0						
2200 "	1812	2.0	1812	2.0	1812	3.0						
3300 "	1812	2.0	1812	2.0	1812	3.0						
4700 "	1812	2.0	1812	2.0	1812	3.0						
6800 "	1812	2.0	1812	2.0	1812	3.0						
0.01 μF	1812	2.0	1812	3.0	1812	4.0	2824	3.0	4030	5.0	5040	6.0
0.015 "	1812	2.0	1812	3.0	1812	4.0	2824	3.0	4030	5.0	5040	6.0
0.022 "	1812	2.0	1812	3.0	1812	4.0	2824	4.0	5040	6.0	5040	6.0
0.033 "	1812	2.0	1812	3.0	1812	4.0	2824	5.0	5040	6.0	5040	6.0
0.047 "	1812	2.0	1812	3.0	2220	2.5	2824	5.0	5040	6.0	6054	7.0
0.068 "	1812	2.0	1812	3.0	2220	2.5	4030	5.0	5040	6.0		
0.1 μF	1812	2.0	1812	3.0	2220	3.5	4030	5.0	6054	7.0		
0.15 "	1812	3.0	1812	4.0	2220	4.5	4030	5.0	6054	7.0		
0.22 "	1812	3.0	1812	4.0	2220	4.5	5040	6.0	6054	7.0		
0.33 "	1812	4.0	2220	4.5	2824	5.0	5040	6.0				
0.47 "	1812	4.0	2220	4.5	4030	5.0	6054	7.0				
0.68 "	2220	4.5	2824	5.0	5040	6.0						
1.0 μF	2220	4.5	2824	5.0	6054	7.0						
1.5 "	2824	4.0	4030	5.0								
2.2 "	2824	5.0	5040	6.0								
3.3 "	4030	5.0	5040	6.0								
4.7 "	5040	6.0	6054	7.0								
6.8 "	6054	7.0										

Size code	L ±0.3	W ±0.3	d	a max.	b min.	c max.
1812	4.8	3.3	0.5	1.2	3.5	3.5
2220	5.7	5.1	0.5	1.2	4	4.5
2824	7.2	6.1	0.5	1.2	4	6.5
4030	10.2	7.6	0.5	2.5	6	9
5040	12.7	10.2	0.7	2.5	6	11.5
6054	15.3	13.7	0.7	2.5	6	14

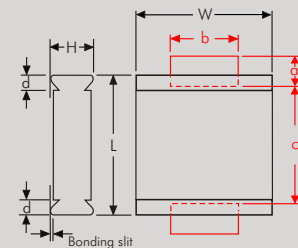

Solder pad recommendation.

*AC voltage: $f = 50 \text{ Hz}$; $1.4 \times U_{\text{rms}} + U_{\text{DC}} \leq U_r$

Dims. in mm.

Taped version see main catalogue

Rights reserved to amend design data without prior notification.

Recommendation for Processing and Application for SMD Capacitors

Layout Form

The components can generally be positioned on the carrier material as desired. In order to prevent soldering shadows or ensure regular temperature distribution, extreme concentration of the components should be avoided. In practice, it has proven best to keep a minimum distance of the soldering surfaces between two WIMA SMDs of twice the height of the components.

Solder Pad Recommendation

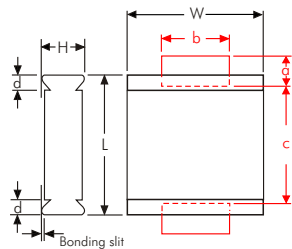

Size Code	L ±0.3	W ±0.3	d	a			b			c		
				min.	min.	max.	min.	min.	max.	min.	min.	max.
1812	4.8	3.3	0.5	1.2	3.5	3.5	1.2	3.5	3.5	1.2	3.5	
2220	5.7	5.1	0.5	1.2	4	4.5	1.2	4	4.5	1.2	4.5	
2824	7.2	6.1	0.5	1.2	4	6.5	1.2	4	6.5	1.2	6.5	
4030	10.2	7.6	0.5	2.5	6	9	2.5	6	9	2.5	9	
4036	10.2	9.1	0.5	2.5	6	9	2.5	6	9	2.5	9	
5040	12.7	10.2	0.7	2.5	6	11.5	2.5	6	11.5	2.5	11.5	
5045	12.7	11.5	0.7	2.5	6	11.5	2.5	6	11.5	2.5	11.5	
6054	15.3	13.7	0.7	2.5	6	14	2.5	6	14	2.5	14	
6560	16.5	15	0.7	2.5	6	15	2.5	6	15	2.5	15	

The solder pad size recommendations given for each individual series are to be understood as minimum dimensions which can at any time be adjusted to the layout form.

Processing

The processing of SMD components

- assembling
- soldering
- washing
- electrical final inspection/ calibrating

must be regarded as a complete process. The soldering of the printed circuit board, for example, can constitute considerable stress on all the electronic components. The manufacturer's instructions on the processing of the components are mandatory.

Soldering Process

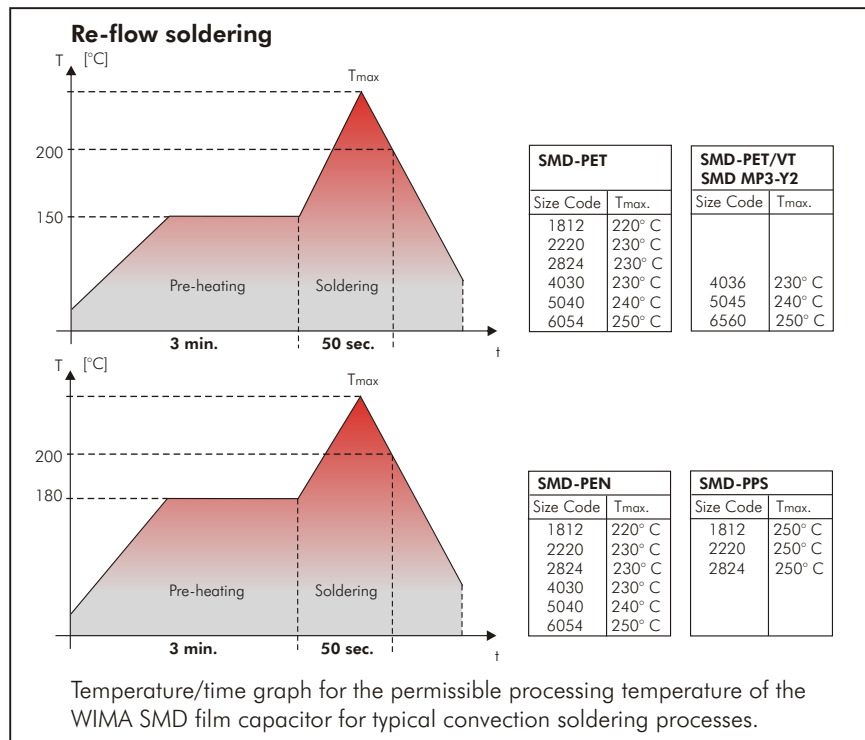

Due to the diverse procedures and the varying heat requirements of the different types of components, an exact processing temperature for reflow soldering processes cannot be specified. The graph is to be understood as a recommendation when

establishing the solder profile according to your actual requirements.

A max. temperature of $T=210^{\circ}\text{C}$ inside the component should not be exceeded when processing WIMA SMD capacitors.

SMD Hand soldering

WIMA SMD capacitors with plastic film dielectric are generally suitable for hand-soldering with a soldering iron where, however, similar to automated soldering processes, a certain duration and temperature should not be exceeded. These parameters are dependent on the physical size of the components and the relevant heat absorption involved.

The below data are to be regarded as guideline values and should serve to avoid damage to the dielectric caused by excessive heat during the soldering process. The soldering quality depends on the tool used and on the skill and experience of the person with the soldering iron in hand.

Size Code	Temperature °C / °F	Time duration
1812	225/437	2 sec tab 1 / 5 sec off / 2 sec tab 2
2220	225/437	2 sec tab 1 / 5 sec off / 2 sec tab 2
2824	250/482	2 sec tab 1 / 5 sec off / 2 sec tab 2
4030/4036	260/500	5 sec tab 1 / 5 sec off / 5 sec tab 2
5040/5045	260/500	5 sec tab 1 / 5 sec off / 5 sec tab 2
6054/6560	260/500	5 sec tab 1 / 5 sec off / 5 sec tab 2



Solder Paste

To obtain the best soldering performance we suggest the use of following solder past alloy:

Lead free solder paste

Sn - Bi
Sn - Zn (Bi)
Sn - Ag - Cu (recommended)

Solder paste with lead

Sn - Pb - Ag (Sn60-Pb40-A, Sn63-Pb37-A)

Washing

Basically, all plastic encapsulated components, irrespective of the brand cannot be considered as being hermetically sealed. They are therefore only suitable for industrial washing processes to a limited extent. During the washing process, washing agents can penetrate the interior of the component by capillary action through microcracks which might have occurred. This is dependent on a number of parameters e.g.

- washing agents
- viscosity of the washing solvent
- temperature/time of the washing process
- mechanical washing aids such as ultrasonic water pressure rinsing and spraying pressure

The type of washing agent to be used is largely specific to the individual user or is often laid down by the manufacturer of the washing equipment. The aggressiveness of the washing agent to be used can thus only be judged in appropriate test series relating to each individual washing process. By and large, the basic rule is that the washing process should be carried out as gently as possible.

Drying

During the washing process, aqueous solutions can penetrate the component. This can lead to changes in the electrical parameters. Suitable drying measures should ensure that no residual moisture or traces of washing substances are left in the component.

Initial Operation/Calibration

Due to the stress which the component are subjected to during processing, reversible parameter changes occur in almost all electronic components. The capacitance recovery accuracy to be expected with careful processing is within a scope of

$$|\Delta C/C| \leq 5\%$$

For the initial operation of the device a minimum storage time of

$$t \geq 24 \text{ hours}$$

is to be taken into account. With calibrated devices or when the application is largely dependent on capacitance it is advisable to prolong the storage time to

$$t \geq 10 \text{ days}$$

In this way ageing effects of the capacitor structure can be anticipated. Parameter changes due to processing are not to be expected after this period of time.

Humidity Protection Bags

Taped WIMA SMD capacitors are shipped in humidity protection bags according to JEDEC standard, level 1 (EMI/static-shielding bags conforming to MIL-B 81705, Type 1, Class 1). Under controlled conditions the components can be stored two years and more in the originally sealed bag. Opened packing units should be consumed instantly or resealed for specific storage under controlled conditions..

Reliability

Taking account of the manufacturer's guidelines and compatible processing, the WIMA SMD stand out for the same high quality and reliability as the analogous leaded WIMA series. The technology of metallized film capacitors used e.g. in WIMA SMD-PEN achieves the best values for all fields of application. The expected value is about:

$$\lambda_0 \leq 2 \text{ fit}$$

Furthermore the production of all WIMA components is subject to the regulations laid down by ISO 9000 as well as the guidelines for component specifications set out by IEC quality assessment systems for electronic components (IECQ-CECC).

Electrical Characteristics and Fields of Application

Basically the WIMA SMD series have the same electrical characteristics as the analogous leaded WIMA capacitors. Compared to ceramic or tantalum dielectrics WIMA SMD capacitors have a number of other outstanding qualities :

- favorable pulse rise time
- low ESR
- low dielectric absorption
- available in high voltage series
- large capacitance spectrum
- stand up to high mechanical stress
- good long term stability

As regards technical performance as well as quality and reliability, the WIMA SMD series offer the possibility to cover nearly all applications of conventionally leaded film capacitors with SMD components. Furthermore, the WIMA SMD series can now be used for all the demanding capacitor applications for which, in the past, the use of leaded components was mandatory:

- measuring techniques
- oscillator circuits
- differentiating and integrating circuits
- A/D or D/A transformers
- sample and hold circuits
- automotive electronics

With the WIMA SMD programme available today, the major part of all plastic film capacitors can be replaced by WIMA SMD components. The field of application ranges from standard coupling capacitors to use in switch-mode power supplies as filter or charging capacitors with high voltage and capacitance values, as well as in telecommunications e.g. the well-known telephone capacitor $1\mu\text{F}/250\text{VDC}$.

Blister Tape Packaging and Packing Units of the WIMA SMD Capacitors



Tape reel:

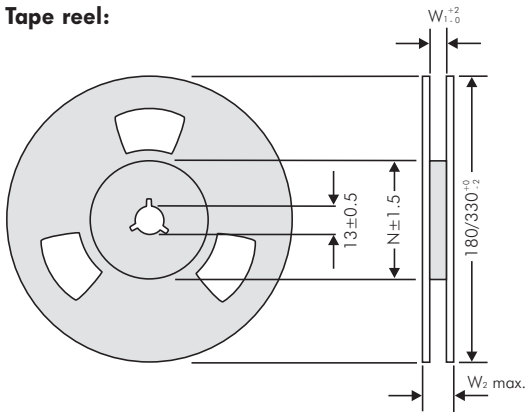

Tape advance and return:

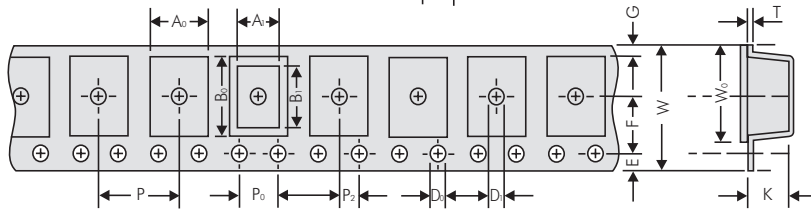
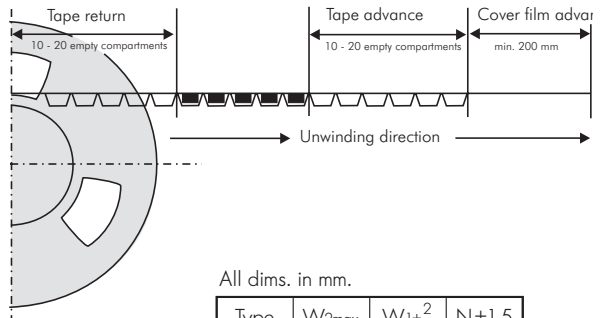

All dims. in mm.

Type	W _{2max}	W _{1±0.2}	N±1.5
1812	19	12.4	62
2220	19	12.4	62
2824	19	12.4	62
4030	22.4	16.4	60
5040	30.4	24.4	90
6054	30.4	24.4	90

Packing units

SMD 1812	A ₀ ±0.1	A ₁	B ₀ ±0.1	B ₁	D ₀ +0.1 -0	D ₁ +0.1 -0	P ±0.1	P ₀ * ±0.1	P ₂ ±0.05	E ±0.1	F ±0.05	G	W ±0.3	W ₀ ±0.2	K ±0.1	T ±0.1
Box size																
4.8x 3.3x 2	3.55	3.3	5.1	4.8	∅1.5	∅1.5	8	4	2	1.75	5.5	2.2	12	9.5	2.8	0.3
4.8x 3.3x 3	3.55	3.3	5.1	4.8	∅1.5	∅1.5	8	4	2	1.75	5.5	2.2	12	9.5	3.4	0.3
4.8x 3.3x 4	3.55	3.3	5.1	4.8	∅1.5	∅1.5	8	4	2	1.75	5.5	2.2	12	9.5	4.4	0.3

taped Reel 180 mm ∅	taped Reel 330 mm ∅	bulk
1000	3000	1000
750	2500	1000
500	2000	1000

SMD 2220	A ₀ ±0.1	A ₁	B ₀ ±0.1	B ₁	D ₀ +0.1 -0	D ₁ +0.1 -0	P ±0.1	P ₀ * ±0.1	P ₂ ±0.05	E ±0.1	F ±0.05	G	W ±0.3	W ₀ ±0.2	K ±0.1	T ±0.1
Box size																
5.7x 5.1x 2.5	6.1	5.7	5.6	5.1	∅1.5	∅1.5	8	4	2	1.75	5.5	1.95	12	9.5	2.8	0.3
5.7x 5.1x 3.5	6.3	5.7	5.6	5.1	∅1.5	∅1.5	8	4	2	1.75	5.5	1.95	12	9.5	3.7	0.3
5.7x 5.1x 4.5	6.3	5.7	5.6	5.1	∅1.5	∅1.5	8	4	2	1.75	5.5	1.95	12	9.5	4.7	0.3

taped Reel 180 mm ∅	taped Reel 330 mm ∅	bulk
800	3000	1000
500	1800	1000
400	1500	1000

SMD 2824	A ₀ ±0.1	A ₁	B ₀ ±0.1	B ₁	D ₀ +0.1 -0	D ₁ +0.1 -0	P ±0.1	P ₀ * ±0.1	P ₂ ±0.05	E ±0.1	F ±0.05	G	W ±0.3	W ₀ ±0.2	K ±0.1	T ±0.1
Box size																
7.2x 6.1x 2	6.4	6.1	7.7	7.2	∅1.5	∅1.5	8	4	2	1.75	5.5	0.9	12	9.5	2.8	0.3
7.2x 6.1x 3	6.6	6.1	7.7	7.2	∅1.5	∅1.5	12	4	2	1.75	5.5	0.9	12	9.5	3.4	0.3
7.2x 6.1x 4	6.6	6.1	7.7	7.2	∅1.5	∅1.5	12	4	2	1.75	5.5	0.9	12	9.5	4.4	0.3
7.2x 6.1x 5	6.6	6.1	7.7	7.2	∅1.5	∅1.5	12	4	2	1.75	5.5	0.9	12	9.5	5.4	0.4

taped Reel 330 mm ∅	bulk
3000	1000
1500	1000
1000	1000
750	1000

	A ₀ ±0.1	A ₁	B ₀ ±0.1	B ₁	D ₀ +0.1 -0	D ₁ +0.1 -0	P ±0.1	P ₀ * ±0.1	P ₂ ±0.05	E ±0.1	F ±0.05	G	W ±0.3	W ₀ ±0.2	K ±0.1	T ±0.1
SMD 4030	10.7	10.2	9.7	9.1	∅1.5	∅1.5	16	4	2	1.75	7.5	1.9	16	13.3	5.9	0.3
SMD 4036	10.7	10.2	9.7	9.1	∅1.5	∅1.5	16	4	2	1.75	7.5	1.9	16	13.3	5.9	0.3
SMD 5040	13.2	12.7	12.1	11.5	∅1.5	∅1.5	16	4	2	1.75	11.5	4.7	24	21.3	7.0	0.3
SMD 5045	13.2	12.7	12.1	11.5	∅1.5	∅1.5	16	4	2	1.75	11.5	4.7	24	21.3	7.0	0.3
SMD 6054	17.0	16.5	15.6	15.0	∅1.5	∅1.5	20	4	2	1.75	11.5	2.95	24	21.3	7.5	0.3
SMD 6560	17.0	16.5	15.6	15.0	∅1.5	∅1.5	20	4	2	1.75	11.5	2.95	24	21.3	7.5	0.3

taped Reel 330 mm ∅	bulk
775	500
775	500
600	200
600	200
450	200
450	200

* cumulative after 10 steps ± 0.2 mm max.
Samples and pre-production needs on request or 1 Reel minimum.