

vifa DX25TG05-04

Nominal impedance [ohm]-----4
 Voice coil resistance [ohm]-----2.75
 Long term max power [W]-----140W/3000*
 Sensitivity [dB]-----93.5
 Frequency range [Hz]-----1500-40000
 Free air resonance [Hz]-----650
 Voice coil diameter [mm]-----25
 Air gap height [mm]-----2
 Eff. diaphragm Area [cm?]-----7.0
 Moving mass [g]-----0.42
 Force factor [Bl]-----2.2
 Qms-----4.32
 Qes-----0.79
 Qts-----0.67

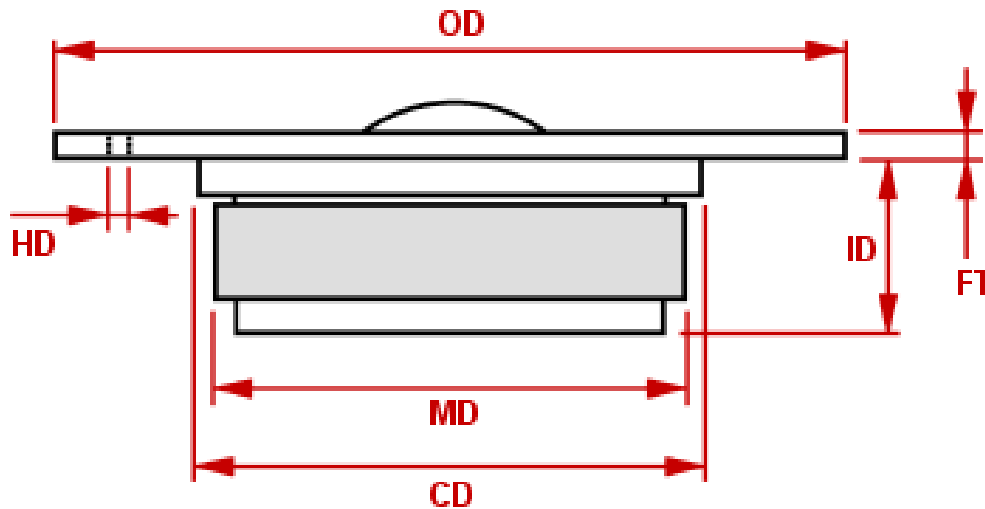

OD:104 mm
FT:5 mm
CD:84
MD:71
ID:28
HD:4

SPL [dB]

